

SPECIAL ISSUE

73

Kenya Gazette Supplement No. 14

13th February, 2026

(Legislative Supplement No. 10)

LEGAL NOTICE NO. 11

THE TRAFFIC ACT

(Cap. 403)

THE TRAFFIC (SCHOOL TRANSPORT) RULES, 2026

ARRANGEMENT OF RULES

Rule.

PART I—PRELIMINARY PROVISIONS

- 1—Citation and commencement.
- 2—Interpretation.
- 3—Object and purpose of the Rules.
- 4—Application of the Rules.

PART II—LICENSING OF SCHOOL TRANSPORT PROVIDERS
AND SCHOOL VEHICLES

- 5—School transport provider's licence.
- 6—School vehicle road licence.
- 7—Suspension and revocation of licences.
- 8—Short-term school vehicle road licence.

PART III—OBLIGATIONS OF SCHOOL TRANSPORT
PROVIDERS

- 9—Obligations of school transport providers.
- 10—School vehicle attendants.
- 11—Crossing guards.

PART IV—SCHOOL VEHICLES

- 12—Requirements for school vehicles.
- 13—Reflectorised red stop mechanical signal arms.

14—Telematic system.

15—Requirements for seats.

16—Windows.

PART V—SCHOOL VEHICLE DRIVERS AND SCHOOL VEHICLE ATTENDANTS

17—Qualifications of a school driver.

18—Role of school vehicle drivers.

19—Qualifications of a school vehicle attendant.

20—Role of school vehicle attendants.

PART VI—PROCEDURES FOR OPERATION OF SCHOOL VEHICLES

21—Hours of operation of school vehicles.

22—Permitted passengers in school vehicles.

23—Boarding and alighting.

24—Discipline.

25—Designated places for boarding and alighting.

26—Safe stopping areas.

27—Occupancy of the driver's seat.

28—Doors to be closed and latched.

29—Handling vehicle keys.

30—Undesirable materials.

31—Aisles and exits to be kept clear.

32—Passengers to be seated.

33—Safety and compliance checks.

34—Stop signal and red light.

PART VII—USE OF MOTORCYCLES TO TRANSPORT SCHOOL-GOING CHILDREN

35—Protective gear and luggage.

PART VIII—MISCELLANEOUS PROVISIONS

36—Appeals.

37—Offences and penalties.

THE TRAFFIC ACT
(Cap. 403)

IN EXERCISE of the powers conferred by section 105B(3) of the Traffic Act, the Cabinet Secretary for Roads and Transport, makes the following Rules—

THE TRAFFIC (SCHOOL TRANSPORT) RULES, 2026

PART I—PRELIMINARY PROVISIONS

1. These Rules may be cited as the Traffic (School Transport) Rules, 2026, and shall come into operation as follows—

Citation and commencement.

- (a) rules 13 and 14, on the 1st July, 2026; and
- (b) all the other rules, on the date these Rules are published in the *Gazette*.

2. In these Rules, unless the context otherwise requires—

Interpretation.

“Appeals Board” means the Transport Licensing Appeals Board established under section 39 of the National Transport and Safety Authority Act;

Cap. 404.

“Authority” means the National Transport and Safety Authority established under section 3(1) of the National Transport and Safety Authority Act;

“crossing guard” means a person whose job is to help people including schoolchildren go across busy streets safely;

“institution of basic education and training” has the meaning assigned to it in section 2 of the Basic Education Act;

Cap. 211.

“independent school transport provider” means an independent individual or entity engaged by an institution of basic education and training, an institution of higher education or a parent for the purpose of providing transportation of students;

“institution-operated transport provider” means an institution of basic education and training or an institution of higher education that owns and operates a school vehicle for the purpose of transportation of students;

“schoolchild” means a student in an institution of basic education and training;

“school transport provider” means an independent and institution-operated school transport provider;

“school vehicle” means a motor vehicle used for the transportation of students;

“school vehicle attendant” means any person employed for the purpose of assisting children to safely embark and disembark from a school vehicle and for the purpose of assisting the school vehicle driver with maintaining proper student behaviour on the school vehicle;

“school vehicle driver” means a person who drives a school vehicle for the purpose of transporting students to or from an institution of basic education and training or an institution of higher education or the institution’s activities and shall not include a parent who transports a child to the institution;

“school vehicle road licence” means a licence issued in respect of a school vehicle allowing it to operate on a public road;

“stop signal arm” means a device that can be extended outwards from the side of a school vehicle to provide a signal to other motorists not to pass the vehicle because it has stopped to load or discharge students;

“student” means an individual who is enrolled in an institution of basic education and training or an institution of higher education on a full-time or part-time basis;

“telematics” means the use of communications and information technology to transmit, store and receive data from devices to remote objects over a network; and

“qualified medical practitioner” means a medical practitioner registered in accordance with the Medical Practitioners and Dentists Act and accredited in accordance with the Occupational Safety and the Health Act.

3. The object and purpose of these Rules is to provide a framework for the regulation, management and safe operation of school vehicles and transportation of passengers including students in school vehicles.

4. (1) These Rules shall apply to all school vehicles.

(2) These Rules shall not apply to the transportation of a student by a parent, legal guardian or a person given permission by the parent or legal guardian of a student.

PART II—LICENSING OF SCHOOL TRANSPORT PROVIDERS AND SCHOOL VEHICLES

5. (1) Any person intending to offer school transport services shall apply to the Authority in the prescribed form and pay the fee specified in the First Schedule.

Cap. 253.
Cap. 236A.
Object and
purpose of the
Rules.

Application of the
Rules.

School transport
provider’s licence.

(2) An application under sub-rule (1) shall be accompanied by copies of the following documents—

- (a) in the case of a company, the certificate of registration as a company under the Companies Act; Cap. 486.
- (b) in the case of a co-operative society or a Sacco society, the certificate of registration under the Co-operative Societies Act; Cap. 490.
- (c) in the case of a natural person, the national identity card;
- (d) in the case of a business or partnership, the certificate of registration;
- (e) in the case of an institution of basic education and training, the certificate of registration issued under the Basic Education Act; Cap. 211.
- (f) the Personal Identification Number certificate of the applicant issued under the Tax Procedures Act; and Cap. 469B.
- (g) proof of ownership by the applicant of the school vehicles intended to be used to provide school transport services.

(3) The application under sub-rule (1) shall state—

- (a) the postal address of the applicant;
- (b) the office address of the applicant; and
- (c) email and telephone contacts of the applicant.

(3) A school transport provider's licence issued under these Rules shall be valid for a period of one year and may be renewed for a similar period.

(4) The Authority shall issue a successful applicant with a school transport provider's licence but where the application is declined, the Authority shall notify the applicant in writing specifying the reasons thereof.

(5) The Authority may impose such conditions as it may consider necessary in respect of a licence issued under this rule.

6. (1) A person shall not offer school transport services unless—

- (a) that person is the holder of a school transport provider's licence; and

School vehicle
road licence.

- (b) the school transport services are offered using a school vehicle issued with a valid school vehicle road licence.

(2) A holder of a valid school transport provider's licence intending to offer school transportation services using a school vehicle shall apply to the Authority for a school vehicle road licence from the Authority in the prescribed form and pay the fee specified in the First Schedule.

(3) Where a holder of a valid school transport provider's licence intending to offer school transportation services using more than one school vehicle, that person shall apply to the Authority for a separate school vehicle road licence in respect of each other school vehicle.

(4) An application for a school vehicle road licence shall be accompanied by copies of the following documents—

- (a) a valid school transport provider licence in the name of the applicant; and
- (b) a valid inspection certificate in respect of the school vehicle issued not more than thirty days before the date of the application.

(5) The Authority shall issue a successful applicant with a school vehicle road licence but where the application is declined, the Authority shall notify the applicant in writing specifying the reasons thereof.

(6) A school vehicle road licence issued under these Rules shall be valid for a period of one year from the date of issue and may be renewed on or before the expiry of that period.

(7) The Authority may impose such conditions as it may consider necessary in respect of a licence issued under this rule.

7. (1) The Authority may suspend or revoke a licence issued under these Rules where the holder of the licence contravenes any provision of the Act, these Rules or the conditions imposed on the licence under these Rules.

Suspension and
revocation of
licences.

(2) Before suspending or revoking a licence, the Authority shall—

- (a) furnish the holder of the licence with written reasons for the intended suspension or revocation; and
- (b) give the holder of the licence an opportunity to make representations against the intended revocation or suspension.

(3) The Authority shall notify the holder of a licence of its decision in writing and, where the decision is the revocation or suspension of the licence, the Authority shall specify the reasons thereof.

8. (1) Where a school vehicle is on hire or being used for the transportation of persons other than students, the operator shall apply to the Authority for a short-term school vehicle road licence in the prescribed form and pay the fee specified in the First Schedule.

Short-term school vehicle road licence.

(2) The Authority may impose such conditions as it may consider necessary in respect of the temporary school vehicle road licence issued under this rule.

PART III—OBLIGATIONS OF SCHOOL TRANSPORT PROVIDERS

9. Each holder of a school transport provider's licence shall—

Obligations of school transport providers.

- (a) ensure each school vehicle has, at a minimum, third-party motor vehicle insurance;
- (b) employ school vehicle drivers and school vehicle attendants licensed or authorised in accordance these Rules;
- (c) ensure each school vehicle is properly maintained and serviced and shall keep a record of the maintenance and service records in respect of each school vehicle for the preceding two years;
- (d) develop and adopt a school transport operations policy which, at the minimum, shall provide for—
 - (i) transport operations, fleet management and logistics;
 - (ii) school vehicle driver recruitment, supervision, management and capacity development;
 - (iii) road safety awareness creation and training for school vehicle drivers and school vehicle attendants;
 - (iv) measures to ensure that a school vehicle driver shall not continuously operate a school vehicle for more than a total of eight hours in any period of twenty-four hours;
 - (v) measures to ensure that a school vehicle driver shall take a break of at least four hours in any period of

twenty-four hours where the driver operates or intends to operate the school vehicle for cumulative period of eight hours;

- (vi) maps of school transport routes; and
 - (vii) emergency response procedures including procedures for evacuation, medical emergency and communication with parents, guardians and school authorities during any incident affecting school vehicles and passengers in the school vehicles; and
- (e) be required to submit a school vehicle accident report within twenty-four hours after an accident involving the school vehicle which results in a death and the report shall contain—
- (i) a brief description of the accident;
 - (ii) a passenger manifest with the names of the passengers and their identification numbers, if applicable;
 - (iii) details of the school vehicle driver or the person operating the school vehicle at the time of the accident; and
 - (iv) motor vehicle insurance particulars of the school vehicle.

10. Where the holder of a school transport provider's licence is an institution of basic education and training, that holder of the licence shall employ a school vehicle attendant in respect of each school vehicle.

School vehicle attendants.

11. (1) In addition to the obligations of the holder of a school transport provider's licence under rules 10 and 11, where the holder of the licence is an institution of basic education and training, that holder of the school transport provider's licence shall designate a person to be a crossing guard to direct, control and manage traffic at the areas of entry into and exit out of the school.

Crossing guards.

(2) The institution of basic education and training shall, in respect of the crossing guard designated under sub-rule (1)—

- (a) ensure that the crossing guard has undergone the necessary training and possesses the necessary skills to act as a crossing guard; and

- (b) ensure that the crossing guard possesses appropriate tools and equipment including a reflective jacket and traffic control sign.

(3) A crossing guard shall have the power to direct, manage and control traffic around the areas of entry and exit from the institution of basic education and training including the power to—

- (a) stop motorists to allow students to cross a road to and from the institution;
- (b) stop motorists to allow a school vehicle carrying students to enter or exit from the institution; and
- (c) direct motorists around the institution to ensure smooth flow of traffic.

(4) A crossing guard, when controlling, directing or managing traffic under these Rules shall—

- (a) wear a reflective jacket;
- (b) carry and use stop and go signs; and
- (c) exercise due care to ensure the safety of students, motorists and other road users when using the road.

(5) Any person who fails to comply with the directives of a crossing guard commits an offence.

PART IV—SCHOOL VEHICLES

12. Each school vehicle issued with a school vehicle road licence and operated by a school transport provider shall—

Requirements for school vehicles.

- (a) have, at a minimum, a third-party motor vehicle insurance cover;
- (b) undergo annual inspection;
- (c) when transporting students of students of an institution of basic education and training, have on board the vehicle a school vehicle attendant and be equipped with a stop sign for use by the school vehicle attendant;
- (d) be fitted with functional safety belts of the appropriate standard approved by the Kenya Bureau of Standards designed to be used by students;
- (e) have on board within easy accessibility by the school vehicle driver or school vehicle attendant at least one fire extinguisher—

- (i) conforming to the applicable Kenya standard;
 - (ii) maintained in good and efficient working order; and
 - (iii) that is not expired;
- (f) be fitted with dual red-light indicators—
- (i) on the uppermost part of the front and rear sides of the bus;
 - (ii) that are positioned in one of the configurations shown in the Third Schedule, having been spaced evenly above the vertical centreline of the school vehicle;
 - (iii) that shall be not less than six hundred millimetres apart;
 - (iv) that shall emit a flashing yellow or amber light, with each light in the pair flashing alternately with a frequency of ninety to one-hundred-and-eighty times per minute; and
 - (v) that shall have an isolating switch installed that controls the operation of the flashing lights;
- (g) have the school vehicle printed with the words—
- (i) “SCHOOL BUS” on the front and rear ends of the bus and the words “DO NOT PASS WHEN RED LIGHTS ARE FLASHING” at the rear in block letters at least eight inches in black colour; and
 - (ii) “IN CASE VEHICLE BEING DRIVEN CLARELESSLY, CALL” together with a telephone number for the school transport provider or, where the school transport provider is a school, the school;
- (h) have installed mirrors that enable the school vehicle driver to have adequate visibility of the sides, rear and along both sides of the school vehicle; and
- (i) conform to the standards set out in the Second Schedule.

13. (1) Where a school vehicle is more than thirty feet in length, the school vehicle shall have installed on it reflectorised red stop mechanical signal arms on the front and rear right-hand side as shown in the Third Schedule.

Reflectorised red stop mechanical signal arms.

(2) The reflectorised red stop signal mechanical arm shall have mounting brackets, clips, bolts or other components necessary to the mechanical or electrical operation thereof and shall not obscure more than fifteen per cent of the border of each side of the reflectorised red stop signal mechanical arm.

(3) The rearmost reflectorised red stop mechanical signal arm shall not contain any lettering, symbols or markings on the forward side.

(4) Each side of the reflectorised red stop mechanical signal arm shall have at least two red lamps, one at the extreme top and the other at its extreme bottom, centred on the vertical centreline of the stop arm flashing at the same rate as the dual red-light indicator specified in rule 13(f).

(7) The reflectorised red stop mechanical signal arm shall be located such that when in the extended position—

- (a) it is perpendicular to the side of the bus, plus or minus five degrees;
- (b) its top edge is parallel to and not more than six inches from a horizontal plane tangent to the lower edge of the frame of the passenger window immediately behind the school driver's window; and
- (c) its vertical centreline is not less than nine inches away from the side of the school bus.

14. Each school vehicle shall be fitted with a vehicular telematic system with a passenger-facing camera being included and shall conform with—

Telematic system.

- (a) the applicable Kenyan Standard; and
- (b) the provisions of the Data Protection Act regarding the protection of personal data that may be collected, recorded or stored by the system.

Cap. 411C.

15. Each seat installed in a school vehicle shall—

Requirements for seats.

- (a) be fixed and not foldable;
- (b) be free from sharp edges;
- (c) be upholstered with soft, shock-absorbent and fire-resistant materials; and

- (d) if the seat contains a seat handle, the seat handle shall be covered with a material that prevents injury in any collision.

16. No bars or any other obstruction may be fixed on the windows of a school vehicle, whether from the inside or the outside. Windows.

PART V—SCHOOL VEHICLE DRIVERS AND SCHOOL VEHICLE ATTENDANTS

17. (1) A person is qualified to be a school vehicle driver if that person— Qualifications of a school driver.

- (a) holds a valid school vehicle driver licence issued by the Authority for the category of school vehicle intended to be driven;
- (b) once in each year, has successfully undergone and passed an assessment of criminal record before operating a school vehicle; and
- (c) once in each year, has undertaken and passed a medical test, including a visual, hearing and mental health test, carried out by a qualified medical practitioner before operating a school vehicle.

(2) Any person with—

- (a) a criminal record containing a conviction for any offence in which a child has harmed or injured, or for child abuse; or
- (b) a conviction for driving under the influence of alcohol, a narcotic drug or psychotropic substance,

shall not be qualified to be a school vehicle driver.

18. Each school vehicle driver shall—

- (a) be fully in charge of the school vehicle;
- (b) be responsible for the health, safety and welfare of each passenger in the school vehicle;
- (c) always operate the school vehicle safely and efficiently;
- (d) not consume alcoholic beverages, products containing nicotine including cigarettes or any intoxicating or psychotropic substances while on duty;
- (e) conduct thorough pre-trip and post-trip checks on the school vehicle to ensure that the school vehicle and safety

Role of school vehicle drivers.

equipment are serviceable and that no passenger is left on board at the end of the trip;

- (f) ensure that the school vehicle is clean and secure;
- (g) ensure that any child disembarking from the school vehicle has safely disembarked and has cleared to a safe distance from the school vehicle; and
- (h) use, where installed the reflectorised red stop mechanical signal arm, and the dual red-light indicators when the school vehicle is at least thirty metres from a stop or has stopped on a road to permit passengers to board or alight from the school vehicle.

19. (1) A person is qualified to be a school vehicle attendant if that person—

Qualifications of a school vehicle attendant.

- (a) holds a valid licence as a Public Service Vehicle conductor issued by the Authority;
- (b) has undergone training on child safeguarding; and
- (c) at least once in each year, undergoes and passes an assessment for a criminal record including a criminal record for convictions for child abuse and arrest for violence.

(3) A person is not qualified to be a school vehicle attendant if that person has—

- (a) a criminal record containing a conviction for any offence in which a child has harmed or injured, or for child abuse; or
- (b) a conviction for driving under the influence of alcohol, a narcotic drug or psychotropic substance.

20. Each school vehicle attendant shall—

Role of school vehicle attendants.

- (a) assist passengers in boarding and disembarking from the school vehicle;
- (b) ensure that any passenger disembarking from a school vehicle has safely disembarked and cleared a safe distance from the school vehicle;
- (c) when the school vehicle is in motion, ensure that passengers and equipment in the school vehicle are properly secured;
- (d) continually monitor overall safety of passengers and equipment;

- (e) ensure that the passengers remain seated when the school vehicle is in motion;
- (f) assist the school vehicle driver during unusual traffic conditions and act as a lookout when reversing the school vehicle;
- (g) monitor and report passenger disruptive behaviour according to procedures prescribed by the school or school transport provider;
- (h) assist the school vehicle driver in keeping the interior of the school vehicle clean;
- (i) assist the school vehicle driver with the post-trip inspection to ensure that no passenger is left on board the school vehicle at the end of the trip;
- (j) provide the required special assistance to passengers with disabilities; and
- (k) where necessary, help passengers boarding or disembarking from the school vehicle to cross the road and, where the passengers are children, ensure their safety when crossing the road.

PART VI—PROCEDURES FOR OPERATION OF SCHOOL VEHICLES

21. (1) Each school transport provider shall ensure that school vehicles only operate between 5:00 am and 10:00 pm.

Hours of operation of school vehicles.

(2) Where, due to the circumstances of the case, a school transport vehicle is operated or is likely to be operated before 5:00 am or after 10:00 pm, the school driver shall report to the nearest police station and seek the written permission of the police officer in charge of the station to continue to operate or to operate the vehicle before 5:00 am or after 10:00 pm, as the case may be.

22. No person, other than teachers, parents, guardians, chaperones, school employees or staff, drivers-in-training or substitute drivers, shall be permitted to ride in the school vehicle while students are being transported.

Permitted passengers in school vehicles.

23. The school vehicle driver shall ensure that the school vehicle has come to complete standstill and positioned safely when passengers are boarding or alighting from the school vehicle.

Boarding and alighting.

24. (1) No person, including a student and any other passenger, is permitted to ride outside a school vehicle or in any hazardous location in or outside the vehicle. Discipline.
- (2) The school vehicle driver shall maintain discipline in the school vehicle and report any case of disobedience or misconduct to the school transport operator or school officials, as the case may be.
- (3) The school vehicle driver shall not discharge any student from the school vehicle for indiscipline except at the student's home or school and where the school vehicle so discharges a student, he or she shall notify the school transport operator or school officials shall of such action immediately.
25. The school vehicle driver shall only allow passengers to board or disembark from the school vehicle at designated places and shall allow a passenger to board or alight from the school vehicle at a place other than a designated place only with the prior written permission of the parent, guardian or relative caregiver and approval by the school transport operator or designated school official. Designated places for boarding and alighting.
26. (1) The school vehicle driver shall not stop the school vehicle near the crest of a hill, on a curve in the road, or on any upgrade or downgrade of severe inclination. Safe stopping areas.
- (2) When a school vehicle is stopped for the purpose of boarding or alighting of passengers, the school vehicle driver shall always stop the school vehicle on the left side of the road and as far off the paved or main travelled portion of the road as the condition of the shoulder permits.
27. (1) No person, other than the school vehicle driver, shall be permitted to occupy the driver's seat at any time, whether the school vehicle is in motion or is stationary. Occupancy of the driver's seat.
- (2) No child under the age of twelve years of age shall be permitted to sit in the front passenger seat of a school vehicle unless the seat is equipped with proper child restraints.
28. The school vehicle driver shall ensure that the school vehicle doors are closed and in the latched position while the school vehicle is in motion. Doors to be closed and latched.
29. The school vehicle driver shall not— Handling vehicle keys.
- (a) leave the driver's seat while the engine is running; or

(b) leave the key in the ignition switch.

30. The school transport provider shall ensure that undesirable materials, including posters depicting cigarette or alcohol advertisements or pornography, are not depicted inside or outside the school vehicle.

Undesirable materials.

31. The school vehicle driver and school vehicle attendant shall ensure that the school vehicle's aisle and exits are kept clear of any obstructions.

Aisles and exits to be kept clear.

32. The school vehicle driver and school vehicle attendant shall ensure that each passenger is seated whenever the school vehicle is in motion.

Passengers to be seated.

33. The Authority may conduct safety and compliance checks on school transport providers, school vehicles, school vehicle drivers and school vehicle attendants at any time to confirm compliance with the Act, these Rules and any relevant written law.

Safety and compliance checks.

34. (1) The school vehicle driver shall stop when the stop signal arm has been extended and the red-light indicators on the uppermost part of the front and rear sides of the school vehicle are flashing.

Stop signal and red light.

(2) Any school driver who fails to stop commits an offence and upon conviction shall be liable to the suspension of the school vehicle driver's licence for a period of at least six months.

PART VII—USE OF MOTORCYCLES TO TRANSPORT SCHOOL-GOING CHILDREN

35. (1) Any motorcycle rider carrying a school-going child school shall—

Protective gear and luggage.

(a) use the prescribed protective gear; and

(b) provide and ensure that the school-going child is wearing the prescribed protective gear.

(2) The motorcycle rider shall ensure that any school-going child carried on a motorcycle does not have any luggage in the child's hands and that any luggage is carried in the motorcycle carrier or in a backpack.

(3) The motorcycle rider shall not carry any other luggage unless inside the motorcycle carrier when transporting a school-going child.

PART VIII—MISCELLANEOUS PROVISIONS

36. A person aggrieved by a licensing decision of the Authority taken under these Rules may within fourteen days of receiving the decision appeal to the Transport Licensing Appeals Board. Appeals.

37. (1) A person who contravenes any provision of these Rules commits an offence and is liable on conviction to a fine not exceeding twenty thousand shillings or to imprisonment for a term not exceeding six months or both. Offences and penalties.

(2) The Authority may, where the convicted person is a school vehicle driver, in addition to any other penalty prescribed under these Rules, suspend the driving licence of the convicted person for a period not exceeding six months.

FIRST SCHEDULE [rr. 5(1), 6(2), 8(1)]

Fees

<i>S/No.</i>	<i>No. of passengers</i>	<i>New application (Ksh.)</i>	<i>Renewal (Kshs)</i>
1.	7 or 8 (Including school vehicle driver)	2,750	2,750
2.	9 to 18	3,250	3,250
3.	19 to 25	3,750	3,750
4.	26 and above	4,250	4,250
5.	PSV badge	1,000	1,000
6.	Short-term school vehicle road licence	3,000	—

SECOND SCHEDULE [r. 12(i)]
List of standards for school vehicles

<i>S/No.</i>	<i>Standard</i>	<i>Description</i>
1.	KS 2295-1	Maximum road speed limiters for motor vehicles, Part 1: Performance and installation requirements
2.	KS 2295-2	Maximum road speed limiters for motor vehicles, Part 2: Specification for system and component requirements
3.	KS 372	Road vehicle – Passenger vehicle body constructions – Specifications
4.	KS 2092	First aid kit - Specification
5.	KS 2517	Portable fire extinguishers and fire blankets
6.	DKS 924	Specification for motor vehicle chevrons, decals and strips
7.	KS 1820: 2005	Retro-reflective marking tapes for commercial vehicles and their trailers
8.	KNWA 3006:2024	Vehicle telematics
9.	KS 2295:2023	Speed limiters

THIRD SCHEDULE [rr. 12(f)(ii), 13(1)]

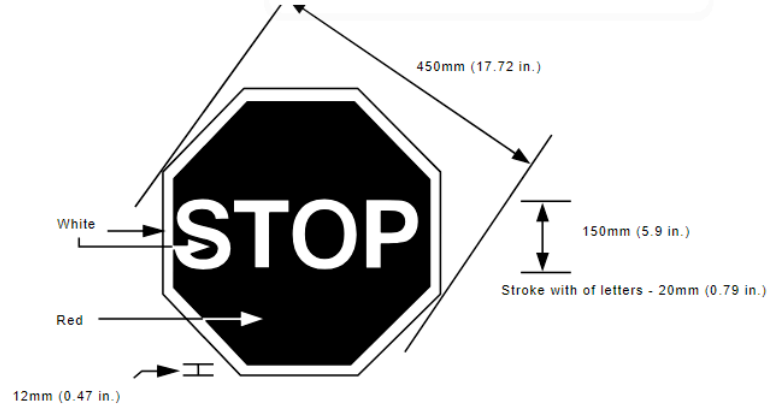
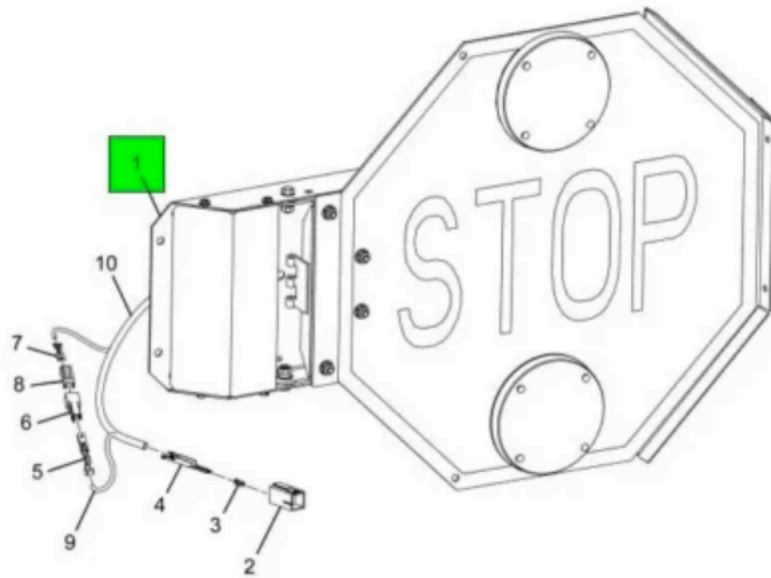
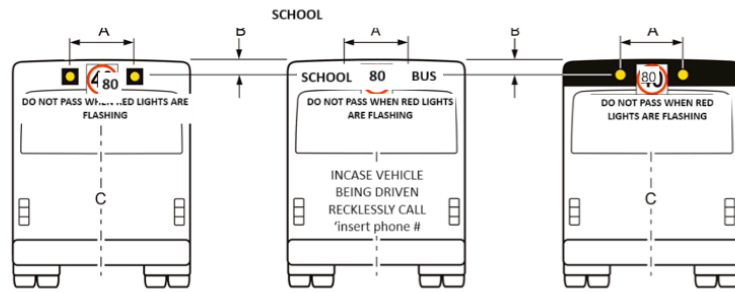
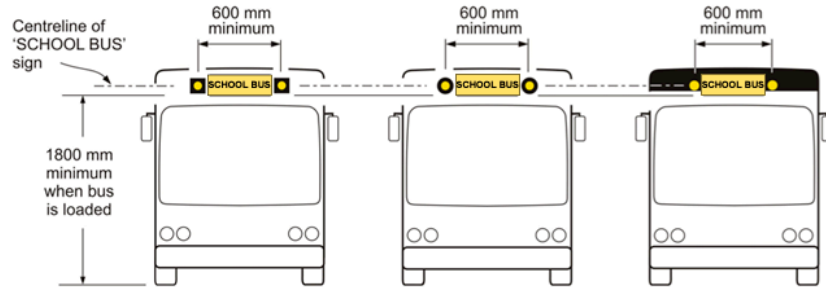

Figure 1. Characteristics of Stop Signal Device





Made on the 9th February, 2026.

DAVIS CHIRCHIR,
Cabinet Secretary for Roads and Transport.